

## Lithium Iron Phosphate (LiFePO4) Battery Specification

### SLAUMXLI12-12(12.8V12AH)



#### Specifications

Nominal Voltage		12.8V
Rated capacity (20 hour rate)		12Ah
Dimensions	Total Height	97.5 mm (3.74inches)
	Height	95 mm (3.74inches)
	Length	151 mm (5.95inches)
	Width	98 mm (3.86inches)
Weight Approx		1.7 Kg (3.75 lbs)
Terminal		T2

#### Characteristics

Capacity Retention		>80% at 28 days
Cycle Life		>80% at 2000 Cycles
Internal Resistance		<50 mΩ
Charge Characteristics	Charge Voltage	14.6±0.1V
	Charger Current	<4A
Discharge Characteristics	Continuous Current	15A
	Discharge Cut-off Voltage	10V
Temperature	Charge Temperature	0°C-45°C(32°F-113°F)
	Discharge Temperature	-20°C-60°C(-4°F-140°F)
	Storage Temperature	0°C-40°C(32°F-104°F)

#### Outer dimensions (mm)

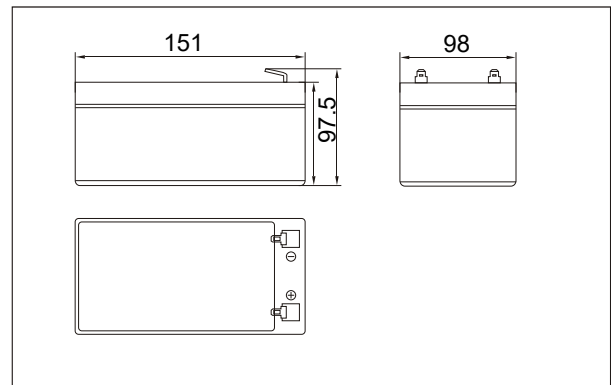

#### Terminal Type (mm)

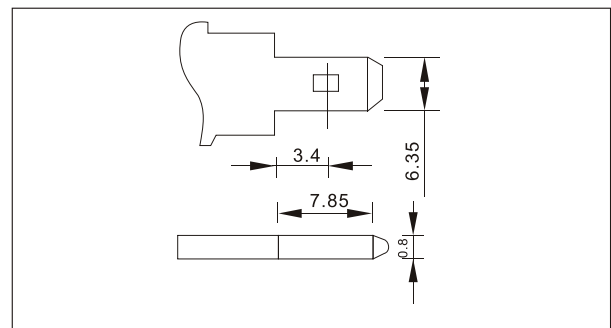

#### Discharge Curves 25°C(77°F)

